

July 15, 1941.

R. S. DANFORTH

2,249,546

TWIN-FLUKE ANCHOR

Filed March 12, 1941

4 Sheets-Sheet 2

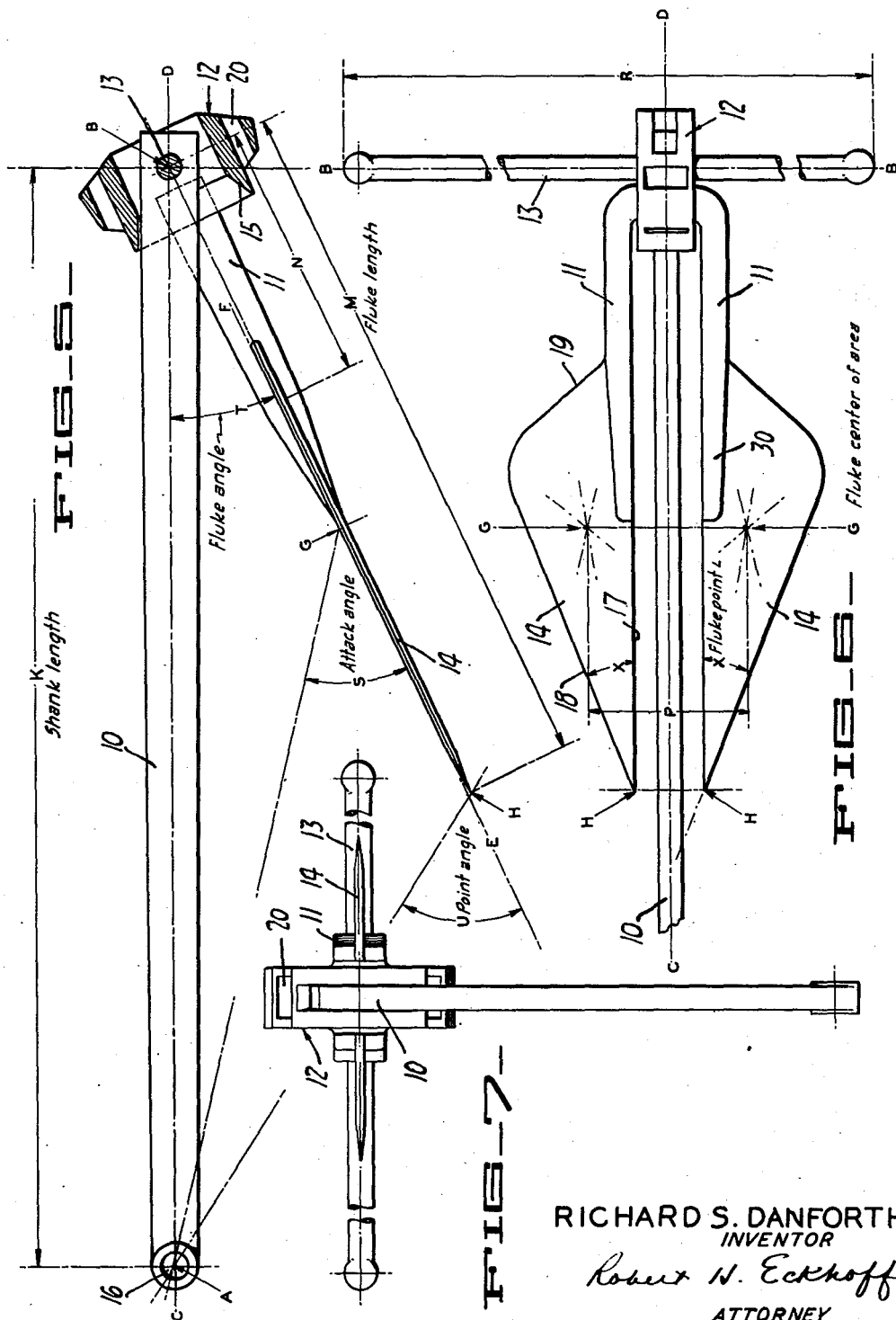

RICHARD S. DANFORTH
INVENTOR

Robert W. Eckhoff

ATTORNEY

July 15, 1941.

R. S. DANFORTH

2,249,546

TWIN-FLUKE ANCHOR

Filed March 12, 1941

4 Sheets-Sheet 3

FIG. 10.

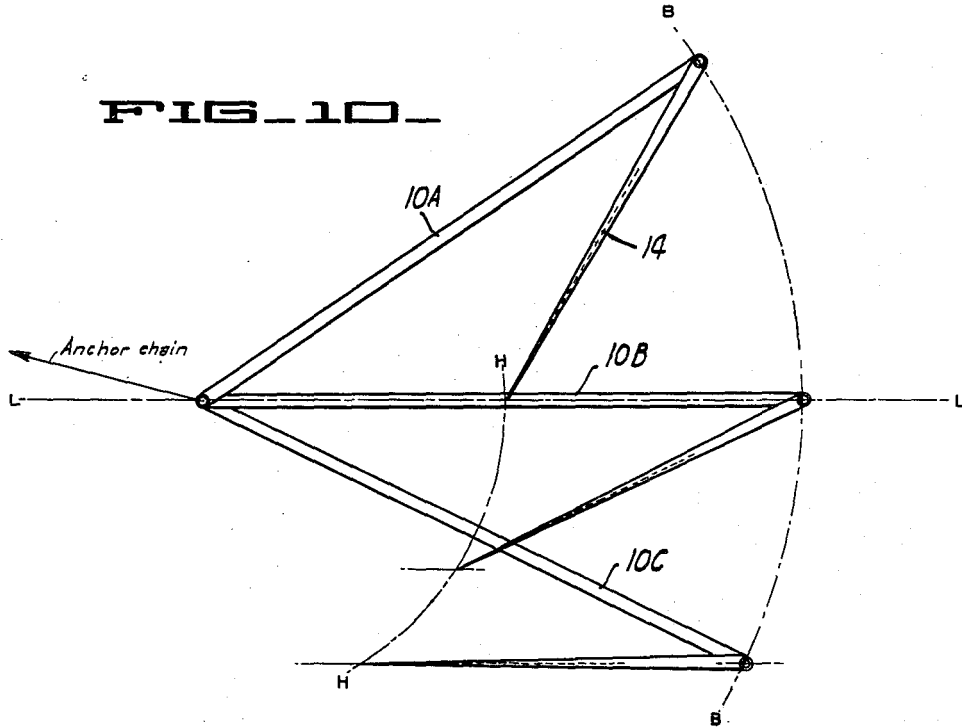

FIG. 8.

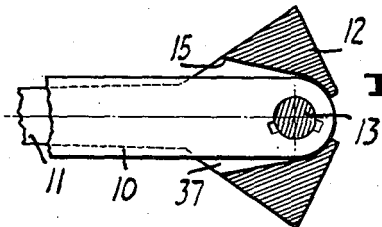
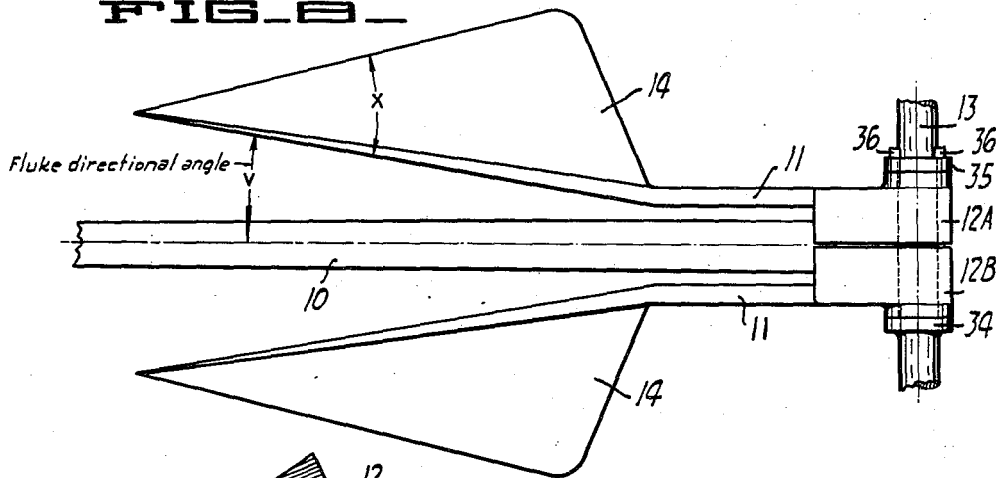

FIG. 9.

RICHARD S. DANFORTH
INVENTOR

Robert W. Eckhoff

ATTORNEY

July 15, 1941.

R. S. DANFORTH
TWIN-FLUKE ANCHOR
Filed March 12, 1941

2,249,546

4 Sheets-Sheet 4

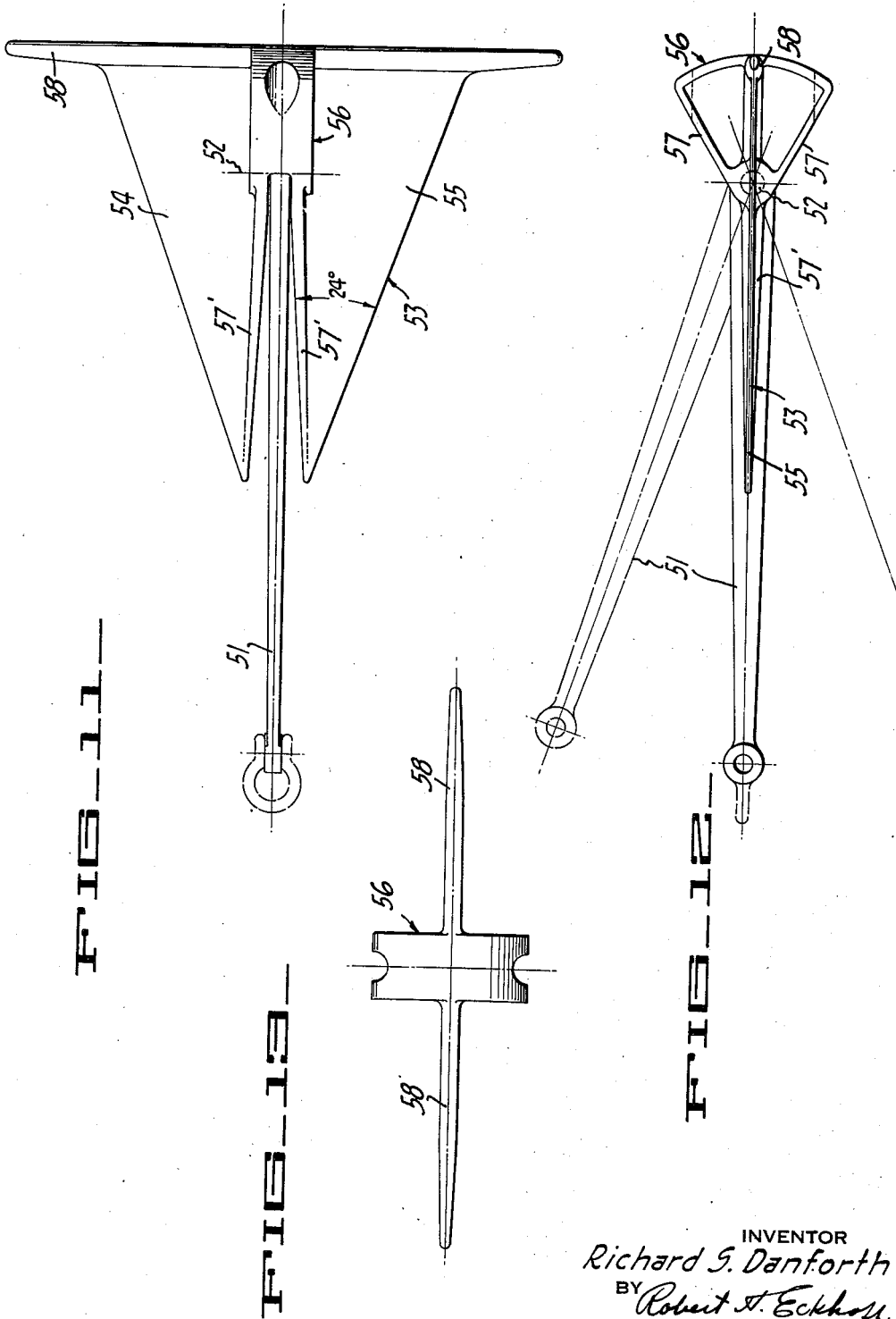

INVENTOR
Richard S. Danforth
BY *Robert J. Eckhoff*
ATTORNEY

UNITED STATES PATENT OFFICE

2,249,546

TWIN-FLUKE ANCHOR

Richard S. Danforth, Berkeley, Calif.

Application March 12, 1941. Serial No. 382,943

15 Claims. (Cl. 114—208)

The present application is in part a continuation of my co-pending application Ser. No. 261,617, filed March 13, 1939, and entitled "Anchors."

For general purposes of classification and to delineate clearly the present invention, anchors can be divided into two groups, the so-called kedge anchor and the stockless anchor. Briefly, the former includes a shank from one end of which projects two oppositely extending curved arms carrying flukes or palms. At the other end, a long bar, the so-called "stock," is positioned in a plane transverse to that of the fluke arms so that one arm and its palm engage the ground. Such an anchor is typically shown in the British Patent No. 6,004 of 1830 to Pering. The Pering anchor (also called the Admiralty anchor because of its use in the British Navy during the nineteenth century) was later modified by Porter so the flukes could pivot on the shank as in United States Patent No. 2,497 of March 18, 1842.

The latter type of anchor, the stockless anchor, is that commonly used today on most merchant ships and by many navies because of the ease with which it can be drawn up into a hawse pipe and held there ready for use. As commonly employed, it omits a stock; it includes a shank and twin fluke arms, usually secured together as a unit, pivoted at one end of the shank whereby both flukes engage the ground together. This anchor has been variously constructed but reference is made for a typical showing to the United States Patent No. 1,366,218 to Steele.

Many anchors of both types have been made and employed heretofore. In general, their holding power, measured in pounds per pound of weight has been low, of the order of from two to ten pounds per pound of weight.

The holding power of an anchor is usually reported together with a reference to the type of bottom on which the test was made; for example, a blue mud, a mud and shale bottom, etc. The anchor would only engage this surface layer and its resistance would largely be merely that attendant upon pulling it through such material. Now as a matter of fact, it has been observed that a hard, relatively compact bottom will be found underneath almost any overlying layer offering only a poor, or at the best only a fair

anchorage with reference to anchor drag resistance.

I have determined that the twin-fluke type of anchor, as compared to the kedge type anchor, is particularly susceptible to modifications which adapt it to continued penetration under continued pull to attain finally deep burial in the compact bottom offering the best anchorage. This is due in part to the ground plowed up by the flukes passing by the sides of the shank instead of against its lower surface and so its burial resistance is lessened; because the undisturbed ground encountered by the shank during burial may pass back between the two flukes, and because there is no nonfunctional fluke to resist burial. In those instances when the hard underlying bottom is at such a depth that the anchor cannot reach it, nevertheless the anchor will penetrate so deeply that it will reach a harder, more compact and more resistive material at a substantial depth to ensure a materially higher holding power than any prior art anchor of similar weight under the same circumstances. In these respects the twin-fluke anchor is far superior to anchors of other types, and particularly to the kedge type of anchor in which the flukes are so arranged that only one of them can enter the ground at a time. Deep burial cannot be attained with any other type of anchor. Herein after I have outlined certain tests and given the results thereon to illustrate the advantage of deep burial and how present anchors fail to attain it. For these and other presently explained reasons the present invention is restricted to improvements in twin fluke anchors wherein the flukes engage the ground more or less simultaneously and cooperate in providing holding power.

In developing an anchor which would bury itself consistently and be reliable in performance in other particulars, I found that merely altering one or two characteristics in various known anchors was insufficient for the anchor so achieved would, in some holding grounds, skid, furrow, rotate, or otherwise exhibit some failing making it unreliable in use. Some of the objectionable failings are as follows:

"Floating" can occur most often on soft and muddy holding ground; the flukes lie flat on the ground surface or even inclined upward and do not fall into operating position even though the

anchor is drawn over the bottom. An anchor of the twin-fluke type may float on hard ground if given only insufficient lift at the fluke end. If grips are provided, as in some anchors, to ensure the anchor does not float, then the anchor generally will not bury because its resistance is too high. "Skidding" occurs when the anchor falls on its side and opens but rides on the forward end of the shank, the point or side of one fluke and the end of the stock, without jiggling in. "Furrowing" occurs in soft mud when the anchor rides along with one fluke superimposed, or nearly so, over the other and with one end of the stock and one fluke only engaged with the ground. "Rotation" can occur in ground of any type; at some point during the seating of the anchor but before it has come to rest the downwardly acting forces applied to the two flukes become unbalanced, whereupon the anchor rotates about the shank axis and frees itself from ground engagement.

The anchor of my invention is sharply distinguished from prior art anchors, and particularly those of the twin-fluke type, heretofore known and employed, by the possession of certain characteristics.

Some of the critical factors which I have found are set forth here by way of example. The order of their appearance hereinafter does not necessarily reflect the order of their importance, for, as a matter of fact, an anchor, to operate satisfactorily, must possess several of the characteristics as will be presently explained.

First, the anchor is of the twin-fluke type in which the shank passes between the flukes and both flukes engage the ground more or less simultaneously and cooperate to provide holding power; to ensure proper fluke engagement and to prevent rotation the anchor is provided with a stock or equivalent means.

Second, I have found that the fluke area must be proportioned relative to the resistance area, both areas being hereinafter further defined with particularity. When attention is given to this relation, in conjunction with the other characteristics, sufficient driving force is provided to cause the anchor to continue its downward penetration through soft holding ground for a relatively indefinite distance or until harder ground is reached. Generally stated, the fluke area should be as large as is practical and the resistance area as small as is feasible. I have found that certain minimum ratios should be observed between these areas to ensure reliable performance.

Third, the flukes in operating position adopt certain definite angular positions. These are presently defined hereinafter in some detail. Taken as a measure of certain anchor operating characteristics, these angular relations have been determined by me to fall within certain values to the end that the fluke surfaces are most effective in their antagonistic functions of (1) producing initial burial with certainty, (2) thereafter urging the anchor downwardly until it is embedded in firm ground and (3) finally, holding the anchor stationary against the cable pull after it has been firmly embedded.

Fourth, rotation of the anchor is prevented by giving attention to two factors. First, the fluke areas are positioned with respect to each other and with respect to the axis of the shank, as hereinafter further explained in detail, to minimize any tendency of the anchor to rotate under pull. Second, the length of the stock relative to the fluke center spacing is held above certain

presently defined limits to overcome any residual rotational tendency. These two factors ensure absence from rotation.

In addition to the foregoing I have found that the reliability of initial engagement is affected by the relation of the stock length to shank length and that to ensure reliable initial engagement this relation must be held within certain limits. Also, the crown of the anchor is so constructed as to ensure engagement without offering excessive resistance to burial. In addition, a novel form of fluke is provided to ensure the requisite fluke area and at the same time a minimum of resistance to penetration, more particularly into hard ground.

These characteristics, particularly the four first enumerated, when suitably correlated and held within the presently discussed and defined limits, have resulted in production of anchors giving the most surprising results in the way of increased holding power per unit of weight—the factor which, when coupled with stability and with dependability of engagement, provides the ultimate measure of value of anchors.

For example, the well known type of anchor commonly called "stockless," and of the structure above described, has in commercial design an average holding power of from two to three pounds per pound of weight, while the highest test values known to me, obtained only with specially designed anchors of this type, are of the order of six pounds per pound of weight. In comparison, the holding power of my anchor is of the order of two hundred or more pounds per pound weight, an improvement of from thirty to one hundred times over previous performance.

The following test figures illustrate the surprising results obtained with anchors embodying the structural features and characteristics set forth above and described in more detail hereinafter.

The tests were made on San Francisco Bay on a bottom having from three to six feet of soft soupy mud with firmer holding ground beneath. The tests were conducted by attaching each anchor to an end of a conventional anchor line and then casting the anchor over the side of the power boat until the anchor touched bottom following which additional line was paid out until the total line length was four to five times the depth of the water. This ratio, line length to water depth, is commonly referred to as scope. It is generally accepted that an anchor should be attached to a boat with a line scope of at least four; scopes of five to twelve are frequently employed. While the anchors typical of this invention operate successfully at these high scope values, I have successfully used scopes as low as 1.5 and 1.8 in hard holding ground. The tests were made with the anchor under water because it has been amply proven that tests of an anchor holding power made in wet sand, as on an exposed beach, are not indicative of the true holding power under water, the condition of actual use.

After the anchor was on the bottom, the power boat was moved ahead slowly, the end of the anchor line on the boat being secured to a suitable pull registering device whereby the pull on the line could be read in pounds. All the anchors tested, except those embodying this invention and identified as Danforth Mark II anchor, soon dragged. The total pull just short of that required to drag the anchor was taken as

the holding power. Each result given is the average of a number of tests.

In the following tests the anchors described as "conventional stockless anchor" and "conventional kedge anchor" were purchased on the market from ship chandler's stock. They are typical anchors of present day manufacture.

	Anchor weight	Holding power	Holding power per pound weight
	Pounds	Pounds	
Conventional stockless anchor.....	50	100	2.0
Conventional kedge anchor.....	75	187	2.5
Patent cast steel kedge.....	28	181	6.5
Patent galv. folding kedge.....	20	288	14.4
Danforth Mark II anchor as accurately shown in Figures 1 thru 4.....	29	6100	210.3

In the last test the measured holding power of the Danforth anchor was without dragging and represented the limit of capacity of the test apparatus. The following tests were made on good holding ground, hard sand, with about the same scopes as above.

	Anchor weight	Holding power	Holding power per pound weight
	Pounds	Pounds	
Conventional stockless anchor.....	100	200	2.0
Conventional kedge anchor.....	75	325	4.3
Patent cast steel kedge.....	28	500	17.9
Patent galv. folding kedge.....	20	420	21.0
Danforth Mark II anchor.....	29	+6000	206.9

In the last test the Danforth anchor could not be dragged within the limit of the testing scale, even after repeated pulls which finally broke a $\frac{3}{8}$ " chain rated at 8000# tensile strength. While these tests indicated a maximum holding power for improved kedge type anchors of about twenty to one, other figures have been published showing ratios as high as sixty to one, by the British Royal Air Force. See "Anchors for Use on Flying Boats," by L. P. Coombes, Air Ministry, R. & M. No. 1449, and "Tests of Full Scale Anchors in Various Sea Beds," by D. F. Lucking, Air Ministry, R. & M. No. 1546.

Holding power is, by definition, resistance to further movement in the direction in which the anchor is being dragged and is dependent both on the areas of the parts being moved through the ground, as projected to a plane normal to the direction of movement, and to the intrinsic resistance of the ground per unit of area. Thus the holding power of any anchor at the surface of a soft mud bottom will be very small, by reason of the low unit resistance of such ground, and to increase the holding power the anchor must continue to penetrate downwardly until firmer ground is encountered.

An anchor as herein described under continued pull continues this downward movement until the entire anchor is buried in firmer ground, no matter how much soft material may overlie it. Some instances have been observed, on bottoms having a thick layer of soft mud overlying sand, in which not merely the entire 29 pound anchor but also as much as twenty-five feet of Manila cable have been carried below the surface of the mud. It is this ability of my anchor to move downward to an indefinite distance in search of firm holding ground which makes its holding power substantially independent of the

nature of the bottom on which the anchor is cast, there being always at some depth good holding ground beneath even the softest mud.

The exact manner in which holding power of the highest order is secured without sacrificing certainty and stability will now be described, with reference to the attached drawings showing preferred form of the anchor of this invention and certain alternative forms. In these drawings,

Figure 1 is a side elevation of a preferred form of my improved anchor, with the flukes in operative position;

Figure 2 is a plan view of the same form, as it would appear when lying on a flat surface;

Figure 3 is a section through the crown 12 of the same form, as on the line 3-3 of Figure 2;

Figure 4 is a cross section through the crown 12, as on the line 4-4 of Figure 2;

Figure 5 is a diagrammatic drawing of a slightly modified form of the anchor, with one side of the crown cut away;

Figure 6 is a plan view projected from Figure 5 and showing the flukes in operative position;

Figure 7 is an end view looking directly at the ends of the fluke;

Figure 8 is a plan view of a form of the anchor in which the flukes are individually pivoted to swing independently and to come into a common plane in the functioning position;

Figure 9 is a side elevation, partly in section, illustrating the pivot mounting of the shank.

Figure 10 is a diagram used to illustrate certain features relating to the attack angle.

Figure 11 is a plan view of a modified form of anchor embodying my invention but in which the flukes are made up in one piece and a portion of the fluke area lies in back of the pivot mounting of the flukes and the shank.

Figure 12 is a side elevation of the anchor shown in Figure 11, while Figure 13 is a rear view thereof.

Referring first to Figures 1 to 4, the anchor consists of three separable parts: a shank 10, a twin-fluke unit comprising the crown 12, fluke arms 11-11 and flukes 14-14, and a stock 13 which passes through the crown and the after end of the shank to act as a pivot for the fluke unit. (Throughout this description and in the claims, the end of the anchor to which the cable is attached will be referred to as the forward end, the end at which the fluke unit is pivoted will be referred to as the after end.) The forward end of the shank is provided with a shackle 16 for the attachment of a chain or cable.

The shank is preferably tapered longitudinally, as illustrated, this form giving the greatest strength at the after end where the maximum bending stresses occur. The stock, which is preferably tapered as shown, passes through holes bored or cored in the after end of the shank and the cheeks 25 of the crown. The cheeks are connected by webs 27 which can be relieved centrally as at 26 to reduce the resistance area. The crown is cored out as at 29 to receive the after end of the shank and the forward looking internal faces 15 are bevelled at the angle which it is desired that the flukes should assume in operating position, e. g., the fluke angle T of Figure 1.

The fluke arms 11-11 and the flukes 14-14 are integral with the crown and with each other and may suitably be formed as a single steel casting. The fluke arms taper forwardly and form a rib 30 along the inner edge of each fluke. The flukes themselves are relatively thin plates, as

for example in the smaller sizes, those less than 150 pounds, range between $\frac{1}{4}$ " thick adjacent the rib and $\frac{1}{8}$ " adjacent the outer edges, for a 30# anchor and up to $\frac{3}{8}$ " and $\frac{1}{4}$ " respectively for a 150# anchor. These edges are bevelled as at 24 to a relatively sharp immediate edge and the fluke should be brought to a sharp point as shown. This combination of thin plate fluke and reinforcing rib, in the triangular form shown, has a high relation of strength to weight and a very desirable penetrating characteristic.

The form of fluke shown in Figure 6 has its inner edge 17 substantially parallel to the shank axis and its forward outer edge 18 diverging at an angle of about 24° from the axis of the shank. The form shown in Figure 2 is essentially the same, the angle of divergence and the parallelism of the major portion of the inner edge being preserved but a small portion of the point of the fluke is bent outwardly for reasons which will be discussed hereinafter.

The bores through the after end of the shank and the cheeks of the crown are provided with grooves 21 so placed that, with the shank in the proper position, they form a continuous channel. The stock is provided with two lugs 22 and 22', the former being of such dimensions as to pass through the channel, the latter being considerably larger. The stock being passed through the bores in the assembled shank and crown, the smaller lug passes through channel 21 to the opposite face of the crown, after which a slight revolution of the stock takes the lug out of register with the channel and prevents its return. The stock is held against return rotation in any convenient manner, as by means of a cotter pin 26 passed through the stock and lugs 30' on the crown to hold the stock against rotation. In this manner of assembling the shock occasioned upon the anchor falling on one end of the stock is taken by the lugs and no stress is thrown on the cotter pin.

The flange or rib 23 on each side of the crown is for the purpose of providing sufficient lift area and may be increased to any desired width.

A very useful though not essential addition to an anchor of this type is the guard indicated at 32 in Figures 1 and 2. This is essentially a flat plate fastened in any manner at the after end of the crown and of such area as to cover the openings 29. This prevents the possibility of the fluke unit becoming jammed by entrance of a pebble or other like element as a piece of wood. The ring 33 is also useful at times in breaking the anchor out if it should become fouled as on a mooring chain; a float line can be secured to this end of an anchor to permit a direct pull thereon.

Figures 8 and 9 illustrate a modification of the above structure in which the flukes are individually pivoted. In this form the crown 12 is divided into halves 12A and 12B, which are mounted face to face on the stock 13. These halves, which are integral with the fluke arms 11-11, are cored out to span the after end of the shank, as at 37 in Figure 9, the internal faces 15 acting as stops to limit the pivotal movement. The stock is provided with a fixed collar or flange 34 and a slip collar 35, the latter being retained by lugs 36-36 in the general manner described in connection with Figure 4, or otherwise as may be preferred as by tack welding.

Figure 8 also illustrates a positioning of the fluke which I have used to advantage in anchors of moderate weight, as for example from 150

to 2,000 pounds. While the flukes illustrated are of the straight form shown in Figure 6, they can also be of the bent-tip pattern illustrated in Figure 2. The distinction from the arrangements previously shown is that the fluke arm is bent, at about the root of the fluke, to produce an angle V between the inner edge of the fluke and the axis of the shank of from about 5° to 15°. The angle X between the inner and outer edges of the fluke can be as hereinafter described. It will be understood that any of these fluke forms and arrangements may be used in either the individually pivoted structure or in the integral twin-fluke unit.

In the modified form of anchor shown in Figures 11 and 12, a shank 51 is provided. This is pivotally mounted as at 52 on the fluke structure generally indicated at 53 and which comprises the two generally triangularly shaped flukes 54 and 55. Fluke structure 53 can be made up in any suitable manner to provide a one piece fluke structure with the shank pivoted therebetween in any suitable manner. At the rear end of the flukes and adjacent the rear edge thereof crown portion 56 is provided. This includes rearwardly sloping faces 57 which engage the ground, as the anchor is drawn forward, and cause the rear end of the flukes to be lifted. The crown surfaces slope rearwardly and slide over the ground, thus effecting the desired rotation of the flukes into operative position while providing a minimum of resistance to burial. An extension 58 is provided on each fluke and integral therewith, the extension serving as a stock. The extension as well as the rear edge portion which it continues is preferably though not necessarily of arcuate contour, so that a minimum resistance area is provided; the flukes can extend to each side along their rearward edges to provide the functional equivalent of a stock.

The flukes 54 and 55 are preferably triangular in outline with the forward edges thereof at approximately an angle of 24°. The inner edge of each fluke is formed with a rib 57' which slopes outwardly away from the adjacent shank at an angle of about 6° to prevent furrowing.

The preceding modification of my anchor will be further discussed hereinafter.

I shall now consider the various angular and dimensional relations which I have found to be essential to or desirable for the production of high holding power coupled with reliability, first defining the terms used. For this purpose I will refer to the diagrams Figures 5 to 8 inclusive, which show an anchor of the same general form as that illustrated by the preceding figures.

In Figures 5 to 8 inclusive: A is the point of the cable attachment; B is the axis of the pivot, in this case the stock 13. The line B-B is the axis of the stock; the line C-D is the axis of the shank.

The line E-F lies in a plane coinciding with the forward or advancing faces of the flukes. The points G-G are the respective centers of area of the flukes. The points H-H are the points or forward ends of the flukes.

The effective shank length is the distance A-B from the point A of cable attachment to the axis of the pivot 13; it is indicated by the dimension K and is referred to herein as the shank length. The measurement M is the distance between the pivot axis B-B and the fluke points H-H and is referred to herein as the overall fluke length. The measurement N, as shown in Figure 5, is a distance from the axis of the pivot, along the axis

of the fluke, equal to 20% of the shank length. In the claims, where reference is made to this measurement, it is of course to be made along the fluke axis. The measurement P between the centers of area G—G of the flukes is termed the fluke center spacing. The measurement R is the overall length of the stock.

The angle S between the plane of the fluke forward faces and a plane passed through the point of cable attachment A and the centers of areas G—G of these faces (these centers being located as hereinafter described) is termed the attack angle.

The angle T between the plane of the fluke forward faces and the axis of the shank is termed the fluke angle.

The angle U between the plane of the fluke forward faces and a plane passed through cable attachment point A and the points or forward ends H—H of the flukes is termed the point angle.

The angle V is the fluke directional angle, between the inner edge of the fluke and the axis of the shank (Figure 8).

The angle X is the fluke point angle, between the inner and outer forward edges of the fluke.

The angle Y is the crown angle (Fig. 1) taken between the crown face and the fluke axis.

The "resistance area" is the total sectional area of the anchor projected parallel to the fluke axis with the flukes open, the projection being made onto a plane normal to this axis. It can be visualized as the shadow cast on level ground by the sun in zenith when the anchor in operating position (the flukes open) is held with the flukes pointing directly toward the sun, and is represented by the entire area in Figure 7.

The "fluke area" is the sum of the areas of the total forward faces of the two flukes.

The several factors primarily characterizing an anchor of my invention will now be discussed, not in the order of their importance, but rather as I believe them logically related.

Relation of fluke area to resistance area

In the development of the anchor of the present invention I found that the fluke area measured, as hereinafter described under "Angular relations" should be relatively large as compared to the resistance area and that, in fact, the fluke area should be at least 40% of the resistance area and preferably 60% or more of the resistance area. When the importance of this relation is considered, it should be apparent that the fluke area must be so proportioned relative to the resistance area as to provide the burial force necessary to overcome the resistance provided by the purely functional portions of the anchor as well as those non-functional portions not contributing to burial but nevertheless essential to the anchor structure.

In those forms of anchors embodying the present invention and particularly shown in Figures 1, 2, 5, 6 and 8, is practically equal to the area while in the structures shown in Figures 11 and 12, due to the relatively large fluke area and the thin sections employed, the fluke area has been increased relative to the resistance area and is over 1.5 times as much as the resistance area.

There is, of course, a limit to which the relation of fluke area to resistance area can be increased, these limits being inherently provided by the requirement that low angularity be provided between the forward edges of the fluke (angle X) as well as by the fact that, as will presently

appear, the fluke spacing relative to the shank must be held within certain limits to avoid rotation and to avoid excessive stock length.

Relation of resistance area to shank length

Deep burial and its attendant high holding power are favored, I have found, by providing a maximum downward driving force acting against a minimum of resistance. From this it follows that the resistance area should be minimized to the greatest extent consistent with the strength required to avoid bending or breakage.

Taking shank length as an approximately fixed quantity for an anchor of any given size, and therefore a basis to which other dimensions may be referred, the resistance area as hereinbefore defined permissible in an anchor of any given size can be expressed as a function of shank length. To avoid comparison of an area with a lineal figure this relation is expressed by comparing the resistance area with the square of the shank length, in similar dimensional units.

Using this manner of comparison I find that generally satisfactory performance can be expected when the resistance area is not greater than 25% of the square of the shank length, and that the optimum performance is obtained by holding the resistance area to less than 13% and even more preferably 10% of the shank length squared. In the forms of my anchor herein described this minimization of resistance is not dependent on materials having an unusually high relation of strength to volume but is primarily accomplished in the shaping and proportioning of the crown, by the use of a thin, narrow and pointed fluke, and, as will presently be discussed, by the location of the flukes at the most favorable distance from the pivot axis. The use of hollow structural sections or high tensile steel will also permit of further weight reductions enabling the holding power per pound of weight to be increased.

Angular relations

Under this heading are discussed several important and critical factors in anchor design.

Possibly the simplest approach is to consider what occurs when an anchor is cast over the side to fall upon and engage the bottom under continued cable pull. Under any consideration the anchor must first engage the ground and then dig into the ground. It should not scratch the ground and drag along with the points of the flukes acting like rake teeth. To provide for reliable initial engagement I have found that the point angle U should be taken into consideration and my experience indicates that a point angle larger than 75° should be avoided for beyond this, while occasional engagement may occur, dependability is not present; preferably this should be below 70°. Since the point angle, according to definition, includes a consideration of shank length and other characteristics, in some instances the point angle can be taken, together with other values indicated herein, as definitive of the present invention.

I have found that in designs suited to stand severe stresses one can desirably locate and provide at least a portion of the fluke area spaced from other functionally important elements of the anchor, but which elements, in and of themselves, instead of contributing to burial, can actually oppose or prevent burial. A very critical point in an anchor's burial occurs when the shank and crown meet the ground as in position 10B in Figure 10. If we assume a selected fluke angle

T, the greater distance the shank and crown are spaced away from the effective fluke area before the shank and crown engage the ground, the deeper the effective fluke portion is in the ground and the firmer the hold it has on the ground to overcome the resistance of the entering shank and crown. Or, if we assume that the attack angle S is maintained of constant value, while the distance between the effective portion of the flukes and the pivot is varied, the greater this distance the more nearly horizontal will be the face of the flukes and the greater the downward driving component of the flukes' faces to overcome the resistance of the entering shank and crown. I have found it preferable that the flukes should be positioned at such a distance from the crown that when the crown comes into contact with the earth, the flukes have penetrated such a distance and have, in their penetration, so worked up the earth that the resistance offered by the crown in engagement with the earth is relatively low as compared to that which is created when the crown engages firm, fresh earth. If the anchor is of very light weight construction and not especially adapted to rugged service, the resistance of the shank and crown can be reduced to permit moving the effective fluke area closer to and even aft of the pivot to secure burial in ground which is not too hard.

In the diagrammatic showing in Figure 10, the position 10A illustrates the anchor in its initial ground engaging position while position 10B illustrates the anchor with the crown in ground engagement, the ground being indicated by the line L—L. For simplicity the several views of the anchor have been shown with the anchor turning around the same pivot point and with the flukes moving over path H—H and the fluke pivot on path B—B. Of course, in practice this is not so because the anchor will move forward and downward between one position and the next. The final position indicated at 10C with the flukes horizontal illustrates lack of sufficient downward driving component of the flukes effective adjacent the forward end of the anchor. The resistance of an anchor and its ability to bury itself in position 10C is very low; an anchor attaining this position would not be satisfactory so far as holding power is concerned. What is desired is that the anchor, as it advances to the left in Figure 10, continues to bury itself in the ground with the shank and the flukes part way between positions 10B and 10C. This can be ensured by having the effective fluke area at such a distance forward of the pivot that the forward end of the shank and its attached cable are carried down and so the anchor attains a position, as it moves down, part way between positions 10B and 10C and does not in any event attain position 10C.

As a result of my investigations I have determined that the attack angle, angle S , should be measured between the fluke forward face and a plane passed through cable attachment point A of the shank and the centers of area G—G of the fluke forward faces. This angle represents the effective angle of opposition of the fluke face to the pull of the cable as transmitted through the point of cable attachment A.

I have further found that one should give attention, in locating the centers of area of the fluke forward faces and in measuring the fluke areas, to an additional factor, namely, the relative location of the area of the fluke. As a reference point I adopt the pivot axis about which the flukes are pivoted on the shank. In the lighter

weight designs discussed above with a very low resistance to ground engagement I have found that a considerable portion of the fluke area may be located behind the pivot. In this case the attack angle can be based on the center of area of the entire fluke forward face, and the entire fluke area considered. This obtains particularly when 35% or more of the fluke forward face is located aft of the pivot as is the case in some forms of the anchor shown in Figures 11, 12 and 13. When less than 35% of the fluke forward face is located aft of the pivot, or, alternatively stated, when more than 65% of the fluke forward face area is forward of the pivot as in Figures 1, 2, 5 and 6, and in some forms of the anchor shown in Figures 11, 12 and 13, I have found that, in locating the centers of area G—G of the fluke forward faces, one should, in considering the attack angle, disregard any portion of the fluke closer to the pivot axis B than one-fifth of the shank length as indicated by "N" in Figure 5. This should also be done when one is considering the fluke area to resistance area relation previously discussed. The center of area of a fluke can be determined by measurement although usually it can be fairly closely approximated by inspection.

We are thus presented with two situations, one in which 35% of the fluke area is located aft of the pivot point. In this instance, particularly exemplified in some forms of the anchor shown in Figures 11, 12 and 13, I have found the governing limitation is the point angle rather than the attack angle. For this reason the attack angle for this form should be kept in the range of 30°–50°. Because of the necessity of having a point angle of less than 75° it will be found that generally the attack angle will run below 45°. This modified form of anchor possesses the advantage that because the fluke area is approximately balanced fore and aft the pivot point, the vertical bending stress placed on the shank is less permitting a lighter shank to be used with less burial resistance. However, because of the necessity of the shank taking care of a heavy side pull, this reduction is not of as great material benefit as might appear.

In the other instance, with less than 35% of the fluke area aft of the pivot point, or, alternatively stated, with more than 65% of the fluke area forward of the pivot, as in some forms of the anchors shown in Figures 11, 12 and 13 and the anchors shown in Figures 1, 2, 5 and 6, the centers of area, in considering the attack angle and the fluke areas, are determined by consideration only of that portion of the fluke area forward of the pivot axis B a distance more than one-fifth of the shank length, for reasons already outlined.

With the center of area thus taken I have found that the attack angle can vary, as I have previously stated, over a range of 40° to 65°. However, for best results I prefer that this angle be held in the range of 43° to 60°. In some instances the extreme values can be employed. For example, when the anchor is intended primarily for use only on hard, sandy bottoms, the angle may be reduced to as low as 40°; below 40° the holding power falls off rapidly. In the other direction where the anchor is intended only for use on soft mud bottoms, attack angles as high as 65° may be employed. However, for all around use and for successful use under all the varying conditions met with in practice, the angle should

be held within the range of 43° to 60° and preferably at about 49°.

Although I have stated that in determining the centers of areas for the attack angle, and in measuring the fluke areas, in those forms shown in Figures 1, 2, 5 and 6 in some forms of the anchors shown in Figures 11, 12 and 13, one should disregard any portion of the flukes closer to the pivot axis than one-fifth of the shank length, I do not wish to be understood as stating that the fluke should not be continued into this region and even up to and beyond the pivot axis. What is important is that a certain given area be provided sufficiently far forward of the pivot axis because, as previously explained, this portion of the fluke is the most effective in providing downward anchor movement before the crown and shank engage the ground. The after fluke portions can also assist in preventing skidding and floating.

Fluke angle

The value of this angle (angle T) is related to attack angle and shank length: i. e., the attack angle may be varied by changing either the shank length or the fluke angle. If the fluke angle be too wide a desired attack angle is liable to require an excessively long shank, which has an advantage in breaking out the anchor by reason of the greater leverage thus applied but is liable to render the anchor too unwieldy to be practical. Conversely, too narrow a fluke angle is liable to give with the desired attack angle a shank so short that the presently discussed point angle is too large for dependable initial engagement.

While I consider the fluke angle of secondary importance, I prefer to keep it within the limits 27° to 42°.

Relation of fluke center spacing to shank length and to stock length

The tendency toward rotation increases, I have found, other factors being constant, as the spacing between the centers of area of the entire flukes (dimension P) increases. For mechanical and other reasons there is, in each size of anchor, and with any given form of fluke, a minimum distance at which these centers can be spaced. I preferably keep this spacing to the minimum by the use of a relatively long and narrow fluke, by placing the inner edge of the fluke as close to the face of the shank as will avoid undue danger of obstruction to the passage of the fluke past the shank and, in the smaller units, by keeping the inner edge of the fluke, or the major part of such edge, substantially straight and parallel to the axis of the shank. In units of larger size, as for example of 150 pounds upwardly, it is sometimes desirable to cause the flukes to diverge forwardly as shown in Figure 8 in order to overcome a tendency for the anchor to furrow on its side in soft mud.

Shank length being taken as an approximate function of anchor size, the center spacing can be described as related to shank length. I have found by experiment that if this spacing (dimension P) exceeds 44% of the shank length (dimension K) the anchor will be unduly unstable and throw an excessive corrective burden on the stock, which in turn increases resistance area by necessitating a longer stock. I prefer to keep this spacing below a third of the shank length.

The fluke center spacing having, for the above reasons, been minimized to the greatest possible extent, some tendency toward rotation will still re-

main. To overcome this tendency and definitely to prevent rotation under all conditions, I have determined that the relation of stock length to fluke center spacing should not be less than two and preferably not less than two and one-half to one or, even better, not less than three to one.

Summation of important characteristics

By way of summary and to further define the anchor of this invention, both with regard to its essential features and certain other features which, while not essential, are nevertheless important, I have indicated heretofore that the following are among the characteristics that should be observed.

A. The fluke area should be not less than 0.4 the resistance area. Preferably it should be not less than 0.6 and even more preferably it should be greater than the resistance area.

B. The resistance area should be less than 25% of the square of the shank length, preferably less than 13%, and more preferably less than 10%, of the square of the shank length.

C. The point angle should be less than 75° and preferably less than 70°.

D. If 35% or more of the fluke area is aft of the pivot point the attack angle should be in the range of 30°-50°; if less than 35% is aft of the pivot point, that is more than 65% of the fluke area is forward of the pivot point, the attack angle should be in the range of 40°-60°.

E. The stock length should be at least twice the distance between the respective centers of area of the fluke and preferably two and one-half or three times this distance.

Other characteristics

Several other characteristics will now be considered. These are of importance, though they do not affect anchor operation to an extent quite comparable to those discussed heretofore.

Relation of stock length to shank length

A minimum relation of stock length to shank length is important to prevent skidding. If the stock be too short the anchor may open on its side and rest on a three point support consisting of one end of the shank, the end of the stock and the point or outer edge of the fluke. Lengthening the stock tends to move the center of gravity outside the base and to cause the anchor to fall flat, in which position initial engagement can take place. The measurement R (stock length) should not be less than about eight-tenths of the shank length (measurement K) to prevent skidding with certainty under adverse conditions.

Relation of fluke length to shank length

The relation of overall length of fluke (including fluke arm, dimension M) to shank length (dimension K) affects the shape of fluke which will include a given area and also affects the attack angle and the point angle. Placing the fluke point too far forward is liable to make the point angle too obtuse for dependable initial engagement and the attack angle too wide for dependable initial and continued burial. On the other hand if the point of the fluke is placed too far aft it will be impossible to provide sufficient fluke area without making the flukes too wide for efficient engagement in hard material.

The relation of fluke length to shank length also affects the distribution of force along the shank to ensure that the anchor buries itself part way between positions 10B and 10C and

does not attain position 10C with the flukes horizontal.

I have found that with less than 35% of the fluke area back of the pivot the overall length of fluke (dimension M) should be not less than about fifty-five percent of the shank length (dimension K) nor greater than about seventy percent of such length. With 35% or more than 35% of the fluke area back of the pivot the fluke length from the pivot to the point can be less than fifty-five percent.

Shape of fluke

The three forms shown in Figures 2, 6 and 8 are alternative and have basic features in common. First, they are all substantially triangular, the form of Figure 6 having only a small portion of the point bent outwardly at an angle between 5° and 15° to provide the form of Figure 2, while in Figure 8 nearly all of the flukes are bent out to a like angle. This has a beneficial effect as regards skidding and is preferable though not essential, the three forms being in other respects substantially identical in function. The approximately triangular shape is preferable because it has a maximum area consistent with a uniformly low resistance to burial. The angle X between the inner and the outer forward edges of the fluke is preferably about 21° to 27°, this being the range within which sufficient fluke area can be provided without too greatly increasing the burial resistance.

Second, the fluke is as thin as the material of which it is made will permit and is substantially uniform in thickness on any line parallel to the shank axis, and is gently tapered in cross section as shown at 14 in Figure 7.

Fluke clearance

The clearance between the fluke and the side of the shank cannot be too small without incurring serious risk of the flukes being held up in a position above the shank by an accumulation of stiff mud or sticky gravel on the shank, which would render the flukes inoperative. I prefer to keep the average clearance between the inner edge of the fluke and the side of the shank at more than two percent of the shank length, and in no case should it be less than one percent of the shank length.

Design of crown

The structure of the crown is important, the form shown in Figure 1 being preferable to the form of Figure 5. In the latter, passages 20 are provided to reduce the resistance area, but this form may dig into the ground prematurely and thus eliminate the lift of the after end by which the points of the flukes are brought into angular contact with the ground to initiate engagement.

In the form shown in Figure 1 the flat smooth face 31 is inclined toward the axis of the fluke and, when dragged forwardly, rides up even on soft ground and thus lifts the after end of the anchor, while offering relatively little resistance to burial. It is wholly essential that the faces arranged to produce lift be sloped upwardly opposite to the direction of dragging. If the angle of the faces is too steep, they act as grips and prevent burial. They are preferably sloped at about 35° and between 25° and 45° is a good range. It is also desirable that they be centrally located, i. e., on or close to the crown. If such faces be spaced any material distance from the crown, even if the disposition is completely sym-

metrical, they are almost certain to set up a tendency toward rotation under certain conditions. On the other hand, any portions of these faces lying directly under or back of the shank are liable to be rendered ineffective by the trenching effect of the forward end of the shank, lift being required solely in advance of engagement and therefore at a time when there is no resistance to cause the forward end of the shank to lift away from the ground. Consequently, the faces producing lift should be symmetrically located as regards the shank axis and as close thereto as is consistent with bearing on ground lying at the sides of the shank.

Contour and location of stock

To provide means for preventing the anchor from riding on its side, for positioning the flukes to engage and enter the ground and for stabilizing the anchor when engaged and preventing rotation, I provide extensions laterally on each side of the shank. In the forms of anchors shown in Figures 1, 2, 5, 6 and 8 this lateral extension is a separable element while in Figures 11, 12 and 13 the lateral extensions are provided as portions of the flukes. In either case, the terms "stock" or "stabilizing bar" are applied herein and in the claims to such laterally positioned means effective to prevent the anchor from riding on its side, to position the anchor so both flukes initially engage the ground, and to stabilize the anchor and prevent rotation.

A stock of circular section or one in which the faces are arcuate in form is preferred as combining strength with minimum resistance. However any form can be used which will not give undue resistance or introduce an unbalancing effect sufficient to cause rotation.

It is also preferable to project the stabilizing bar from the after end of the anchor, as illustrated, though the more common practice of projecting it from the forward end of the shank may be followed if desired. In such location the advantage of being able to stow the anchor by drawing it into a hawse-pipe is lost. A stock forward also increases the resistance to burial of the forward end and thereby increases the inherent tendency of the flukes to assume the ineffective horizontal position shown at 10C in Figure 10.

An anchor constructed in accordance with the above specification and within the limits defined by the appended claims will also be found desirable in the following respects; to-wit: freedom from danger of fouling the cable when the boat is ranging with wind or tide; ability to stow the anchor by hauling it into a hawse-pipe; ability to stow the anchor flat on deck without the necessity for folding of flukes or stock; immediate readiness for use at all times; freedom from risk of damaging the hull when bringing the anchor on deck; great rapidity and entire certainty of engagement in any type of holding ground; ready disengagement when it is desired to weigh the anchor, and a holding power per unit of weight far higher than any heretofore known. The several anchors shown and described herein in Figures 1 through 9 have been set forth correctly with respect to the size, shape and relative relation of the various elements thereof, particularly the showing of the drawings.

To particularly point out and distinctly claim the part, improvement, or combination which I claim as my invention I include each of the following claims:

1. An anchor of the twin fluke type comprising a shank having a forward and an after end, a stock, a pair of flukes pivoted on said shank at said after end with said shank between said flukes, said flukes having faces thereon substantially simultaneously engaging the ground when in operative position, and a crown at the after ends of said flukes having ground engaging portions thereon sloping rearwardly from the flukes at an angle thereto of between 25° and 45° and terminating at a point raised above the fluke faces to slide along the ground and rotate the flukes when the anchor is on the ground with the flukes and shank in substantially the same plane, the resistance area of said anchor, as herein defined, being less than 25% of the square of the shank length.

2. An anchor of the twin fluke type comprising a shank having a forward and an after end with a point of cable attachment at said forward end, a stock adjacent said after end, a pair of flukes, and a pivot mounting said flukes on said shank at said after end with said flukes extending toward said forward end and with said shank between said flukes, said flukes substantially simultaneously engaging the ground when in operative position, each fluke having the major forward portion approximately triangular in outline with the two forward edges approaching each other at an angle approximately between 21° and 27°, said shank and flukes being so proportioned and positioned relative to each other when in operative position that more than 65% of the area of said flukes is forward of said pivot, and a plane, passed through said point of cable attachment and through the centers of area of only those portions of the fluke forward faces lying forward of said pivot a distance greater than 20% of the length of said shank, makes an angle with the plane of said forward fluke faces in the range of substantially 40° to 60°, said stock having an overall length at least twice the distance between the respective centers of area of the entire fluke forward faces, the area of said fluke forward face portions being at least 40% of the resistance area of said anchor, as herein defined.

3. An anchor of the twin fluke type comprising a shank having a forward and an after end with a point of cable attachment at said forward end, a stock adjacent said after end, a pair of flukes, and a pivot mounting said flukes on said shank at said after end with said flukes extending toward said forward end with said shank between said flukes, said flukes substantially simultaneously engaging the ground when in operative position, each fluke having its major forward portion approximately triangular in outline with at least a portion of its inner edge diverging outwardly away from the shank at an angle of between approximately 5° and 15°, said shank and flukes being so proportioned and positioned relative to each other when in operative position that more than 65% of the area of said flukes is forward of said pivot, and a plane, passed through said point of cable attachment and through the centers of area of only those portions of the fluke forward faces lying forward of said pivot a distance greater than 20% of the length of said shank, makes an angle with the plane of said forward fluke faces in the range of substantially 40° to 60°, the resistance area of said anchor, as herein defined, being less than 25% of the square of the shank length and the distance between the respective centers of area of the entire fluke

forward faces is less than 44% of the shank length.

4. An anchor of the twin fluke type comprising a shank having a forward and an after end with a point of cable attachment at said forward end, a stock adjacent said after end, a pair of flukes, and a pivot mounting said flukes on said shank at said after end with said flukes extending toward said forward end and with said shank between said flukes, said flukes substantially simultaneously engaging the ground when in operative position; said shank and flukes being so proportioned and positioned relative to each other when in operative position that (a) more than 65% of the area of said flukes is forward of said pivot and (b) a plane, passed through said point of cable attachment and through the centers of area of those portions of the fluke forward faces lying forward of said pivot a distance greater than 20% of the length of said shank, makes an angle with the plane of said forward fluke faces in the range of substantially 40° to 60°, said stock having an overall length at least two and a half times the distance between the respective centers of area of the entire fluke forward faces and said distance being less than a third of the shank length, the resistance area of said anchor, as herein defined, being less than 13% of the square of the shank length, the total area of said fluke forward face portions being at least 60% of said resistance area, and a plane passed through said cable attachment point and the forward ends of said flukes in operative positions makes an angle with the projected fluke forward faces of less than 75°.

5. An anchor of the twin fluke type comprising a shank having a forward and an after end with a point of cable attachment at said forward end, a stock adjacent said after end, a pair of flukes, and a pivot mounting said flukes on said shank at said after end with said flukes extending toward said forward end and with said shank between said flukes, said flukes substantially simultaneously engaging the ground when in operative position; said shank and flukes being so proportioned and positioned that more than 65% of the area of said flukes is forward of said pivot, the total area of those portions of said flukes forward of said pivot a distance more than 20% of said shank length is at least 40% of the resistance area, as herein defined, and a plane passed through said cable attachment point and the fluke forward ends in operative position makes an angle of less than 75° with the projected fluke forward faces, the distance between the respective centers of area of said entire fluke forward faces being less than a third of the shank length.

6. An anchor of the twin fluke type comprising a shank having a forward and an after end with a point of cable attachment at said forward end, a stock adjacent said after end, a pair of flukes, and a pivot mounting said flukes on said shank at said after end with said flukes extending toward said forward end and with said shank between said flukes, said flukes substantially simultaneously engaging the ground when in operative position, said shank and flukes being so proportioned and positioned relative to each other when in operative position that (a) more than 65% of the area of said flukes is forward of said pivot and (b) a plane, passed through said point of cable attachment and through the centers of area of those portions of the fluke forward faces lying forward of said pivot a distance greater than

20% of the length of said shank, makes an angle with the plane of said forward fluke faces in the range of substantially 40° to 65°, the area of said fluke forward face portions being at least 60% of the resistance area of said anchor, as herein defined, and the distance between the respective centers of area of the entire fluke forward faces is less than 44% of the length of said shank.

7. An anchor of the twin fluke type comprising a shank having a forward and an after end with a point of cable attachment at said forward end, a stock, a pair of flukes, and a pivot mounting said flukes on said shank at said after end with said flukes extending toward said forward end and with said shank between said flukes, said flukes substantially simultaneously engaging the ground when in operative position; said shank and flukes being so proportioned and positioned that more than 65% of the area of said flukes is forward of said pivot, the total area of those portions of said flukes forward of said pivot a distance more than 20% of the shank length is at least 60% of the resistance area, as herein defined, and said stock having an overall length (a) at least two and a half times the distance between the respective centers of area of the entire forward faces of said flukes and (b) not less than eight tenths of the shank length, and a plane passed through said cable attachment point and the forward ends of said flukes in operative position makes an angle with the projected fluke forward faces of less than 75°.

8. An anchor of the twin fluke type comprising a shank having a forward and an after end with a point of cable attachment at said forward end, a stock, a pair of flukes, and a pivot mounting said flukes on said shank at said after end with said flukes extending toward said forward end and with said shank between said flukes, said flukes substantially simultaneously engaging the ground when in operative position; said shank and flukes being so proportioned and positioned relative to each other when in operative position that more than 65% of the area of said flukes is forward of said pivot, a plane, passed through said point of cable attachment and through the centers of area of only those portions of the fluke forward faces lying forward of said pivot a distance greater than 20% of the length of said shank, makes an angle with the plane of said forward fluke faces in the range of substantially 40° to 65°, and the total area of said fluke forward face portions is at least 40% of the resistance area, as herein defined, said stock having an overall length at least twice the distance between the respective centers of area of the entire forward faces of said flukes.

9. An anchor of the twin fluke type comprising a shank having a forward and an after end with a point of cable attachment at said forward end, a stock, a pair of flukes, and a pivot mounting said flukes on said shank at said after end with said flukes extending toward said forward end and with said shank between said flukes, said flukes substantially simultaneously engaging the ground when in operative position, said shank and flukes being so proportioned and positioned relative to each other when in operative position that more than 65% of the area of said flukes is forward of said pivot, a plane, passed through said point of cable attachment and through the centers of area of only those portions of the fluke forward faces lying forward of said pivot a distance greater than 20% of the length of said shank, makes an angle with the plane of said

forward fluke faces in the range of substantially 40° to 60°, said stock having an overall length at least two and a half times the distance between the respective centers of area of the entire forward faces of said flukes, the resistance area of said anchor, as herein defined, being less than 13% of the square of the shank length.

10. An anchor of the twin fluke type comprising a shank having a forward and an after end with a point of cable attachment at said forward end, a stock adjacent said after end, a pair of flukes, and a pivot mounting said flukes on said shank at said after end with said flukes extending toward said forward end and with said shank between said flukes, said flukes substantially simultaneously engaging the ground when in operative position; said shank and flukes being so proportioned and positioned relative to each other when in operative position that more than 65% of the area of said flukes is forward of said pivot, a plane, passed through said point of cable attachment and through the centers of area of only those portions of the fluke forward faces lying forward of said pivot a distance greater than 20% of the length of said shank, makes an angle with the plane of said forward fluke faces in the range of substantially 40° to 60°, and the total area of said fluke forward face portions is at least 60% of the resistance area, as herein defined, said stock having an overall length at least two and a half times the distance between the respective centers of area of the entire forward faces of said flukes.

11. An anchor of the twin fluke type comprising a shank having a forward and an after end with a point of cable attachment at said forward end, a stock adjacent said after end, a pair of flukes, and a pivot mounting said flukes on said shank at said after end with said flukes extending toward said forward end and with said shank between said flukes, said flukes substantially simultaneously engaging the ground when in operative position, said shank and flukes being so proportioned and positioned relative to each other when in operative position that more than 65% of the area of said flukes is forward of said pivot, a plane, passed through said point of cable attachment and through the centers of area of only those portions of the fluke forward faces lying forward of said pivot a distance greater than 20% of the length of said shank, makes an angle with the plane of said forward fluke faces in the range of substantially 40° to 65° and the total area of said fluke forward face portions is at least 40% of the resistance area, as herein defined, said stock having an overall length (a) at least twice the distance between the respective centers of area of the entire forward faces of said flukes, and (b) not less than eight-tenths of the shank length.

12. An anchor of the twin fluke type comprising a shank having a forward and an after end with a point of cable attachment at said forward end, a stock adjacent said after end, a pair of flukes, and a pivot mounting said flukes on said shank at said after end with said flukes extending toward said forward end and with said shank between said flukes, said flukes substantially simultaneously engaging the ground when in operative position; said shank and flukes being so proportioned and positioned that more than 65% of the area of said flukes is forward of said pivot, the total area of those portions of said flukes forward of said pivot a distance more than 20% of said shank length is at least 60% of the

resistance area, as herein defined, and said stock having an overall length at least twice the distance between the respective centers of area of the entire forward faces of said flukes, and a plane passed through said cable attachment point and the forward ends of said flukes in operative position making an angle with the projected fluke forward faces of less than 75°.

13. An anchor of the twin fluke type comprising a shank having a forward and an after end with a point of cable attachment at said forward end, a stock adjacent said after end, a pair of flukes, and a pivot mounting said flukes on said shank at said after end with said flukes extending toward said forward end and with said shank between said flukes, said flukes substantially simultaneously engaging the ground when in operative position, said shank and flukes being so proportioned and positioned relative to each other when in operative position that a plane passed through said cable attachment point and through the points of said flukes makes an angle with the projected forward fluke faces of less than 75°, said stock having an overall length at least twice the distance between the respective centers of area of the entire forward faces of said flukes, the resistance area of said anchor, as herein defined, being less than 13% of the square of the shank length.

14. An anchor of the twin fluke type comprising a shank having a forward and an after end with a point of cable attachment at said forward end, a stock adjacent said after end, a pair of flukes, and a pivot mounting said flukes on said shank at said after end with said flukes extending toward said forward end and with said shank between said flukes, said flukes each having an overall length between 55% and 70% of the shank length and substantially simultaneously engaging the ground when in operative position; said shank and flukes being so proportioned and positioned relative to each other when in operative position that (a) more than 65% of the area of said flukes is forward of said pivot and (b) a plane, passed through said point of cable attachment and through the centers of area of only

those portions of the fluke forward faces lying forward of said pivot a distance greater than 20% of the length of said shank, makes an angle with the plane of said forward fluke faces in the range of substantially 40° to 60°, said stock having an overall length at least twice the distance between the respective centers of area of the entire forward faces of said flukes, the total area of said forward fluke face portions being at least 40% of the resistance area, as herein defined, of said anchor.

15. An anchor of the twin fluke type comprising a shank having a forward and an after end with a point of cable attachment at said forward end, a stock adjacent said after end, a pair of flukes, and a pivot mounting said flukes on said shank at said after end with said flukes extending toward said forward end and with said shank between said flukes, said flukes substantially simultaneously engaging the ground when in operative position, a crown at the after ends of said flukes having ground engaging portions thereon sloping rearwardly from the flukes at an angle thereto of between 25° and 45° and terminating at a point raised above the fluke faces to slide along the ground and rotate the flukes when the anchor is on the ground with the flukes and shank in substantially the same plane, said shank and flukes being so proportioned and positioned relative to each other when in operative position that more than 65% of the area of said flukes is forward of said pivot, a plane, passed through said point of cable attachment and through the centers of area of only those portions of the fluke forward faces lying forward of said pivot a distance greater than 20% of the length of said shank, makes an angle with the plane of said forward fluke faces in the range of substantially 40° to 65°, the total area of said fluke forward face portions is at least 40% of the resistance area, as herein defined, said stock having an overall length at least twice the distance between the respective centers of area of the entire fluke forward faces.

RICHARD S. DANFORTH.